

A B C D E F G H

估價圖面
樣品圖面
○ 參考圖面
承認圖面
更新圖面

表面處理	電鍍	陽極	液烤漆	粉烤漆
膜厚(mm)	≤0.007	≤0.015	≤0.2	≤0.3

扭拉力	材質	鐵件	鋁件	塑膠件
扭力值(kgf/cm)		6	4	6
拉力值(kgf)		15	8	15

Step 1

E193A230960R*6

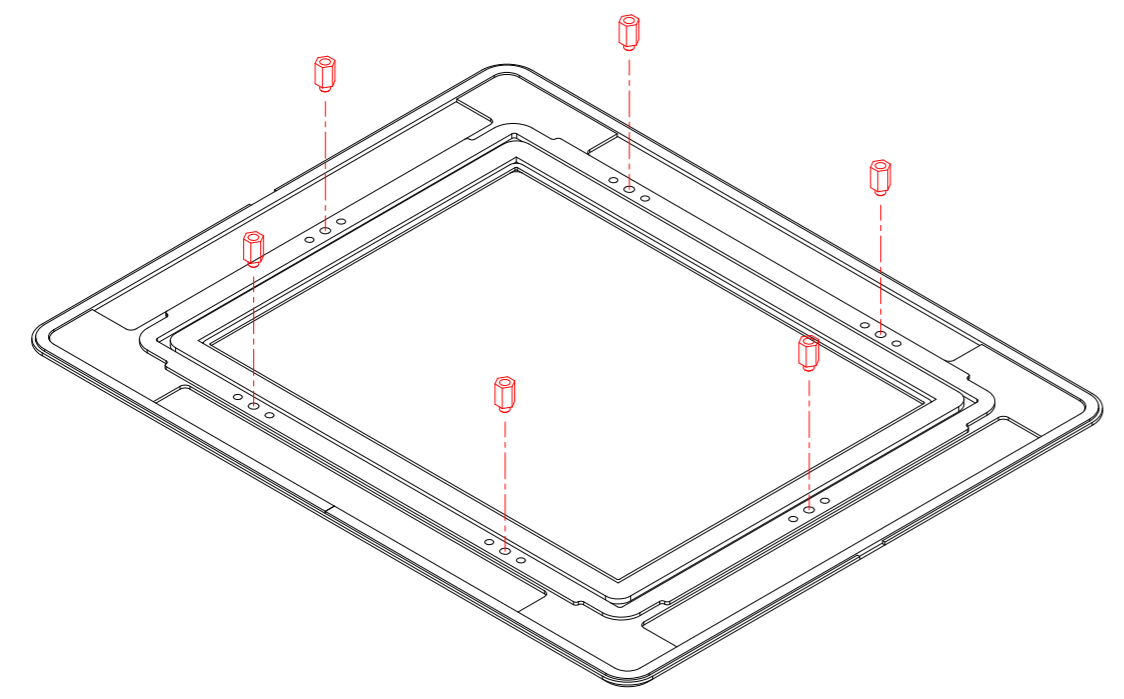

Step 2

E1935030511R*6

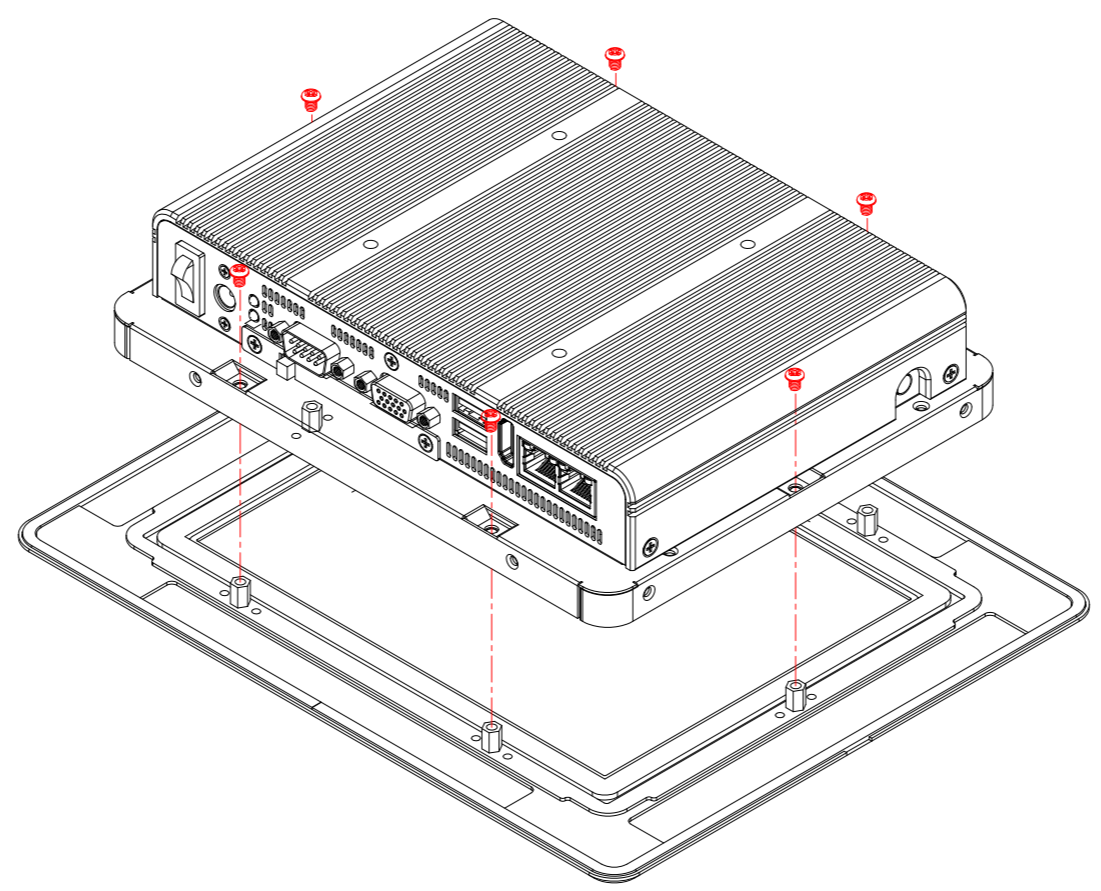

Step 3

E1931030412R*4
E195BMLP080900R*4

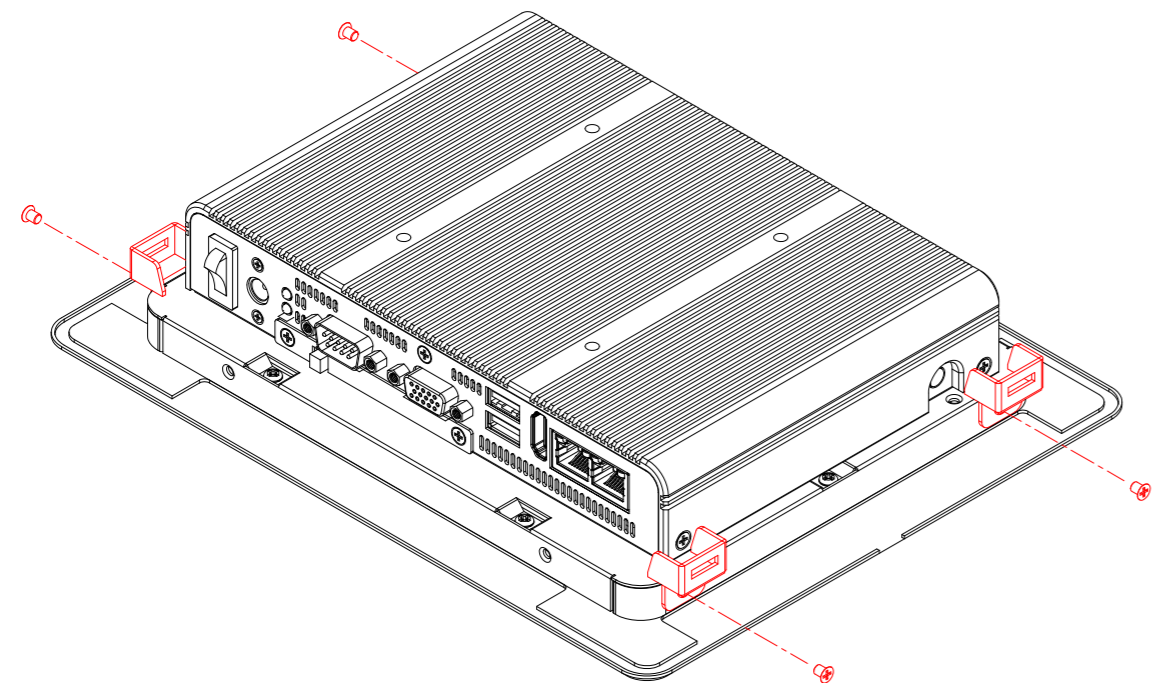

Step 4

E1962LP2018R*4
E1935052510R*4

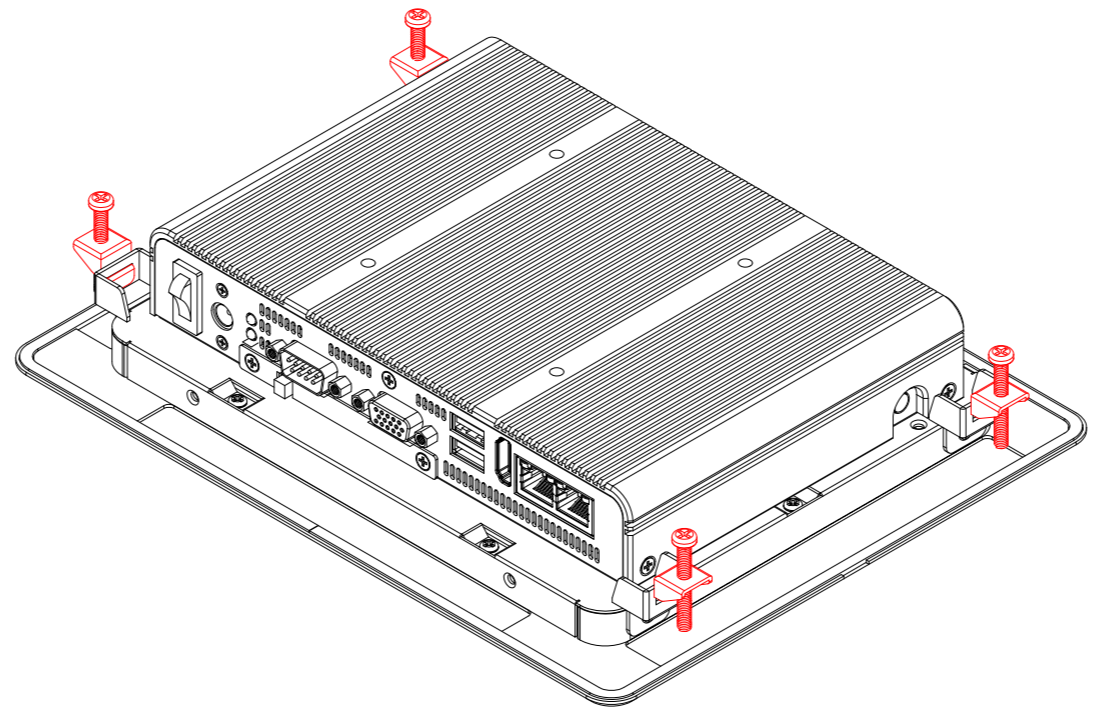

Step 5

E1962LP2018R*4
E199PS00002R*4

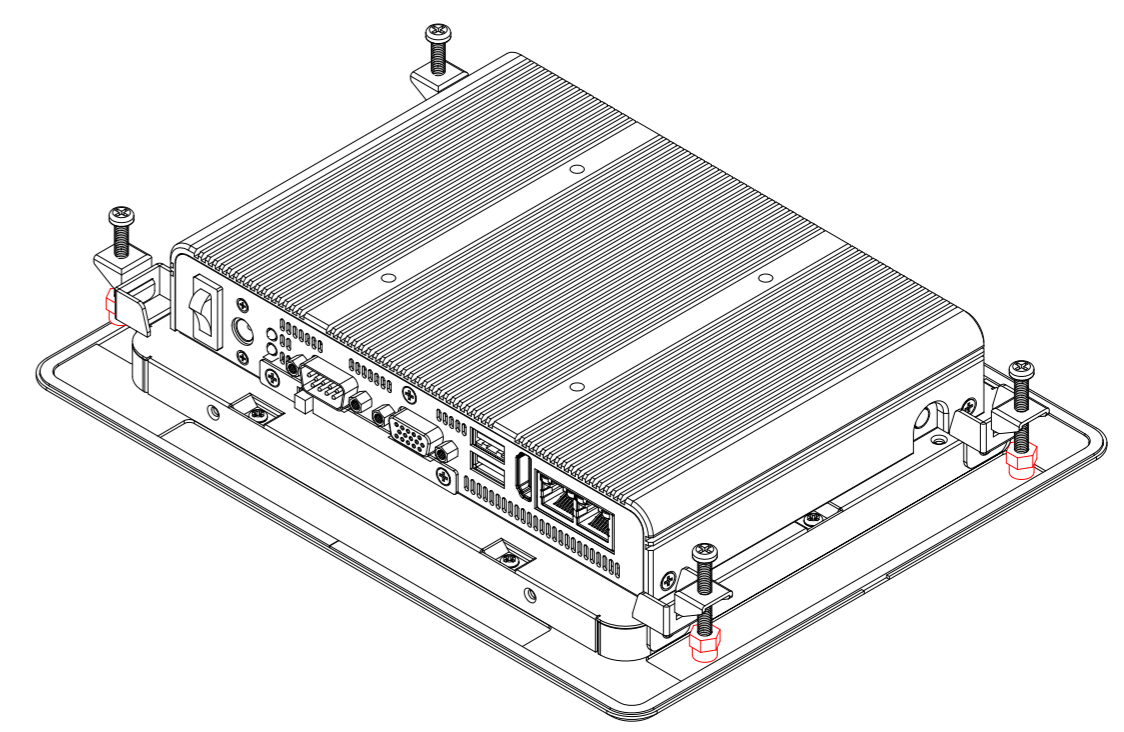

Avalue	L	a	b
Vender	L	a	b
ΔE	≤ 1.5	-1	≤ ΔL、Δa、Δb ≤ 1

GENERAL TOL.	A	B	MATERIAL:	PART No.	20180213				
>0	±0.1	±0.1	SPEC:	TASK DWG No.					
>10	±0.1	±0.2	FINISH:	APPROVED	CHECKED	DESIGNED	DRAWN	NAME	Mount Kit 新裝圖
>50	±0.15	±0.3	UNIT:MM	Dragon Huang	Frank Lu	Jamie Liao	Jamie Liao	MODEL No.	LPC-0809
>200	±0.3	±0.5	SCALE:	1:1	20180213	20180213	20180213	20180213	REV. A1
>500	±0.5	±0.8	ANGLE TOL. ± 0.5					SHEET:	1/1 A2

